

USER'S MANUAL

# CASSETTE SERIES

ASC-12A, ASC-18A





# Operation mechanism and working range.

## ● Working temperature range.

	Indoor side DB/WB (°C)	Outdoor side DB/WB (°C)
maximum cooling	32/23	43/26
minimum cooling	21/15	21/15
maximum heating	27/-	24/18
minimum heating	20/-	-5/-6

## ● Schematic diagram of refrigeration

### 1. Schematic diagram of cooling type

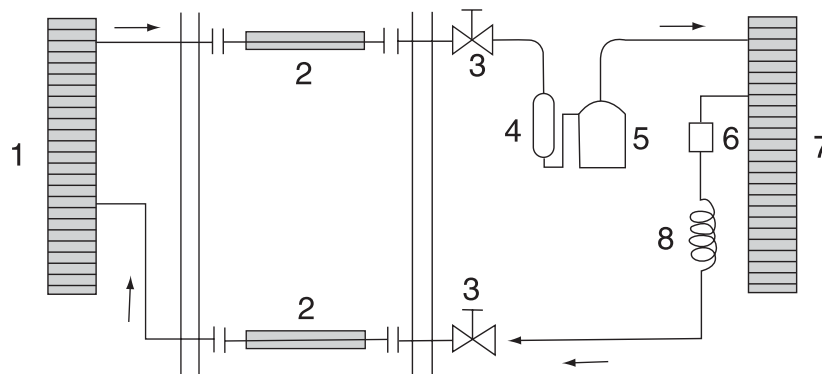

### 2. Schematic diagram of heat pump type

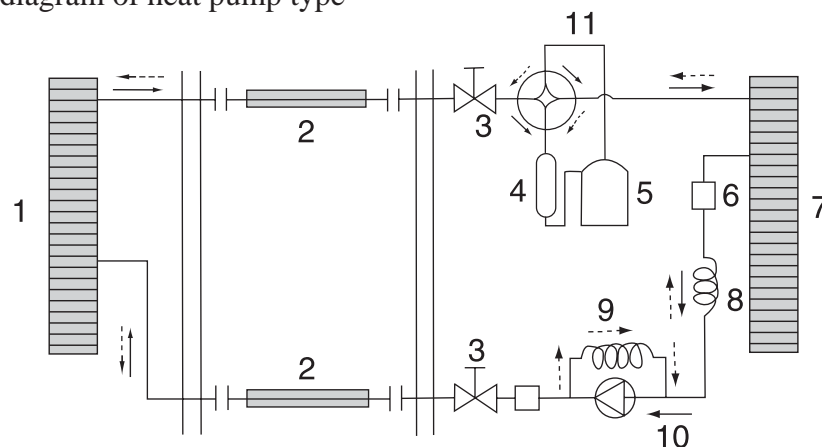

- |                           |                              |                        |
|---------------------------|------------------------------|------------------------|
| 1. Indoor heat-exchanger  | 2. Connecting pipe           | 3. Check valve         |
| 4. Accumulator            | 5. Compressor                | 6. Filter              |
| 7. Outdoor heat-exchanger | 8. Master capillary          | 9. Auxiliary capillary |
| 10. One-way valve         | 11. Four-way reversing valve |                        |

# Names and functions of parts.

## Indoor unit

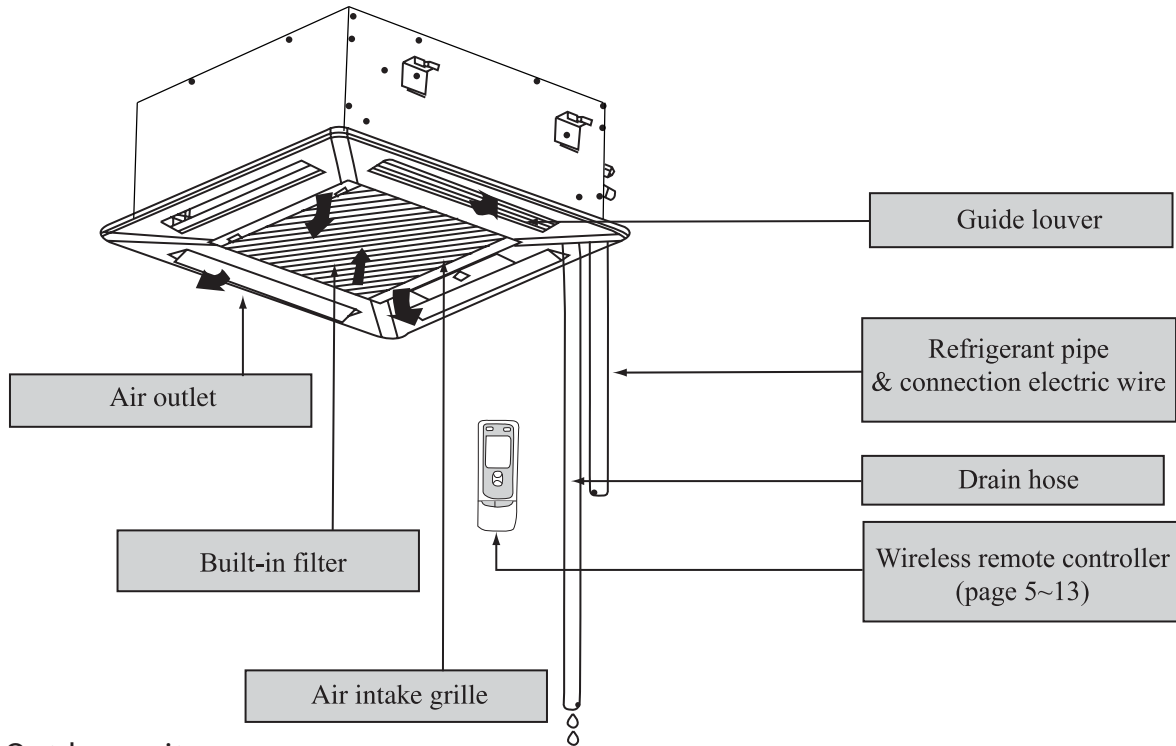

## Outdoor unit

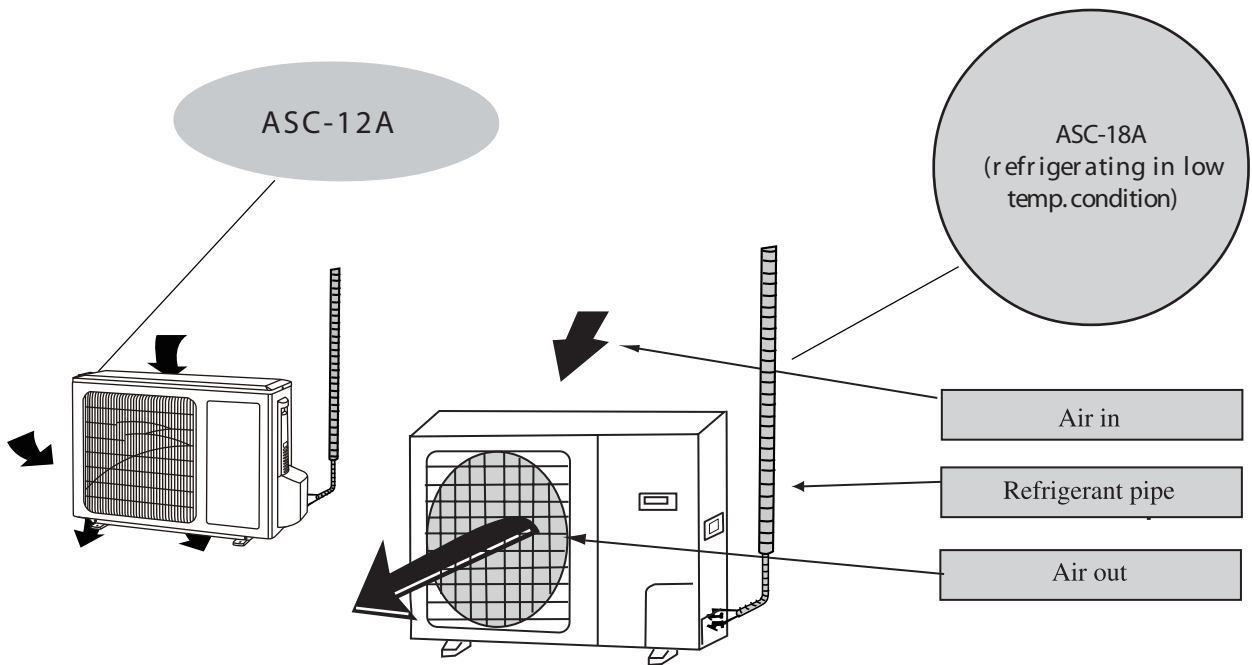

# Safety cautions

● Read the following instructions carefully before use.

## Warning

Avoid direct air flow to your body and avoid excessive heating or cooling, which may make you feel uncomfortable and do harm to your health.

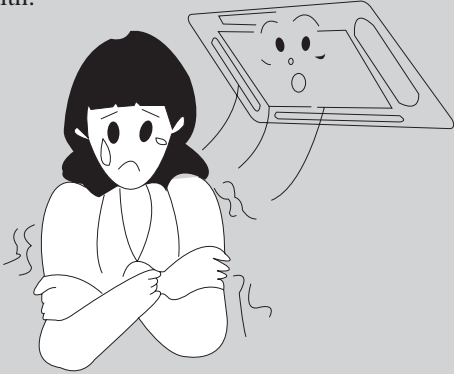

Check whether the installed stand is still firm enough after the unit has operated for a long time. If a worn-out stand is left unfixed, the unit may topple and do harm.

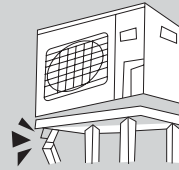

Do not remove protection grill nets from the outdoor unit. Do not reach hands or insert anything into the unit air outlet.

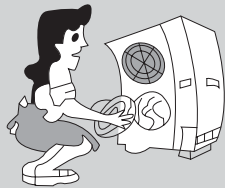

Do not stand on the outdoor unit or put anything on it, or you may fall down or people may get hurt by the falling things.



If there is something abnormal (eg. burning smell), cut off the power immediately and contact service center.



Do not spray any paint or pesticide on the unit, or it may cause fire.

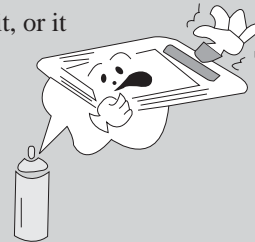

If room air is stuffy, air the room by opening door and window for a while, but please close the curtains when operating the unit to prevent conditioned air from leaking.

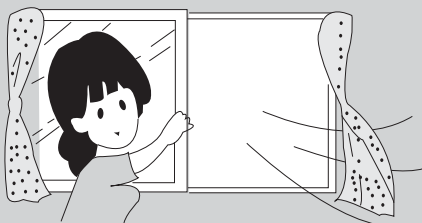

Never use wrong ampere rating wire. Use of iron wire or copper wire may cause the unit to break down or cause fire.

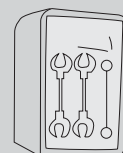

iron wire

# Safety cautions

## Warning

Do not check or repair during the unit is operating. It is very dangerous.

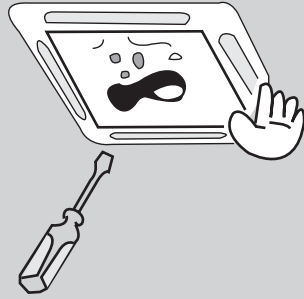

Do not use other heating equipment near the air conditioner. It will affect the cooling performance.



Never place objects near the air intake and the air outlet of the unit. It may affect performance or stop operation of the unit.

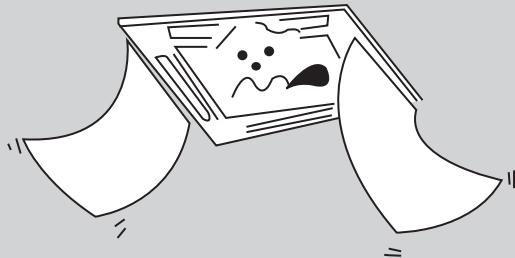

Do not splash water directly to indoor unit. It may cause trouble or electric shock.

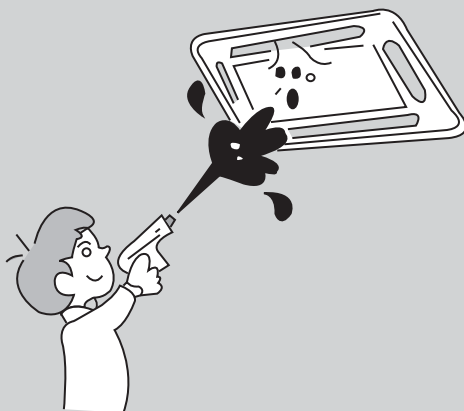

Do not bang the remote controller and do not press the button of the remote controller with pointed object, or the remote controller may be damaged.

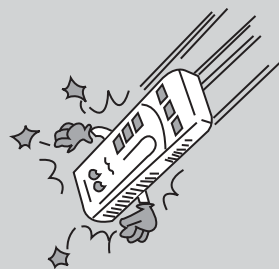

# Remote control operation procedure

## ● Name and Function-Remote control

### Note:

- Be sure that there are no obstructions.
- Don't drop or throw the remote controller.
- Don't place the remote controller directly in the sunlight.

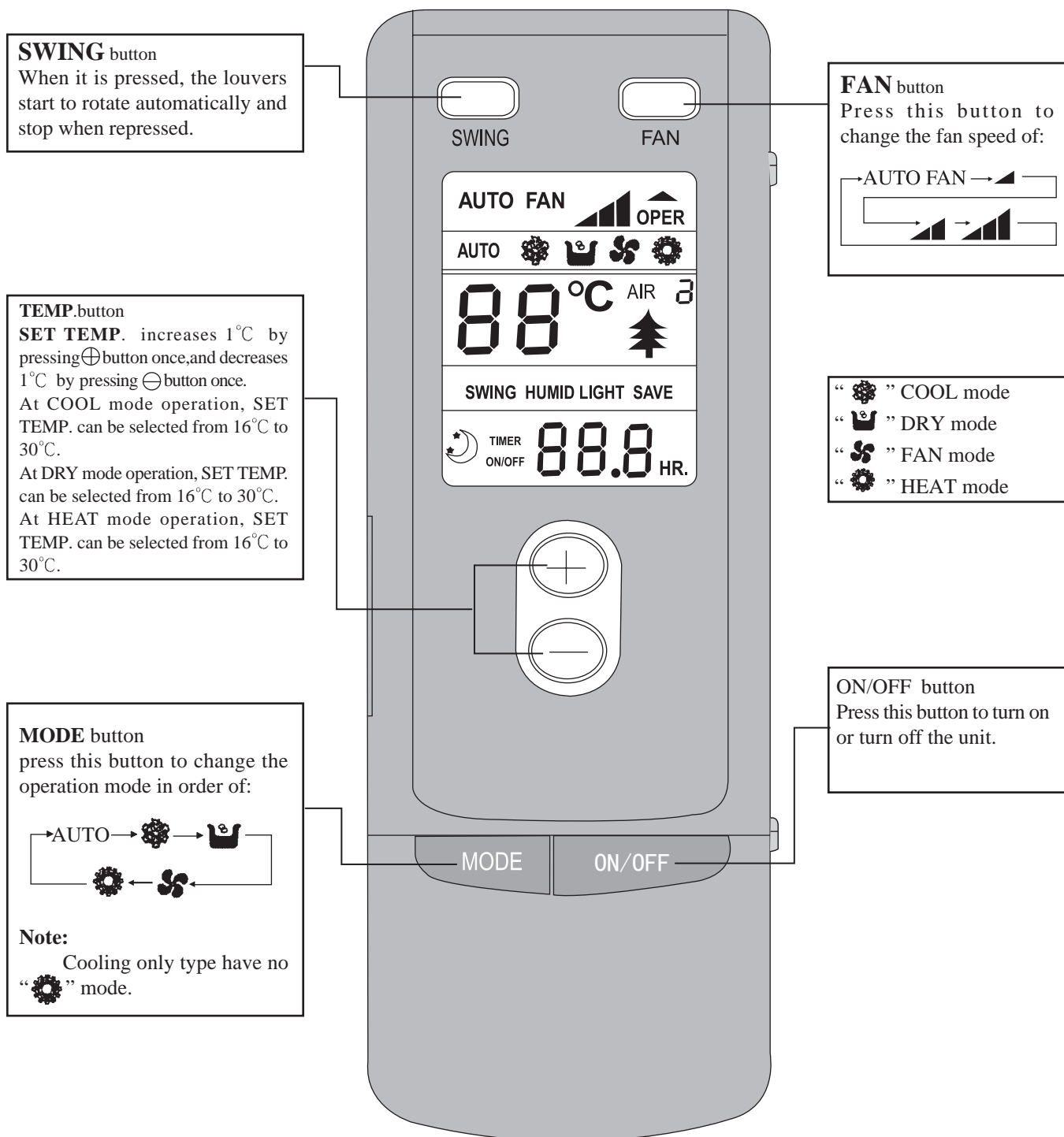

# Remote control operation procedure

Name and Function-Remote control. (Remove the cover)

Note: This type of remote controller is a kind of new current controller. Some buttons of the controller which are not available to this Air conditioner will not be described below.

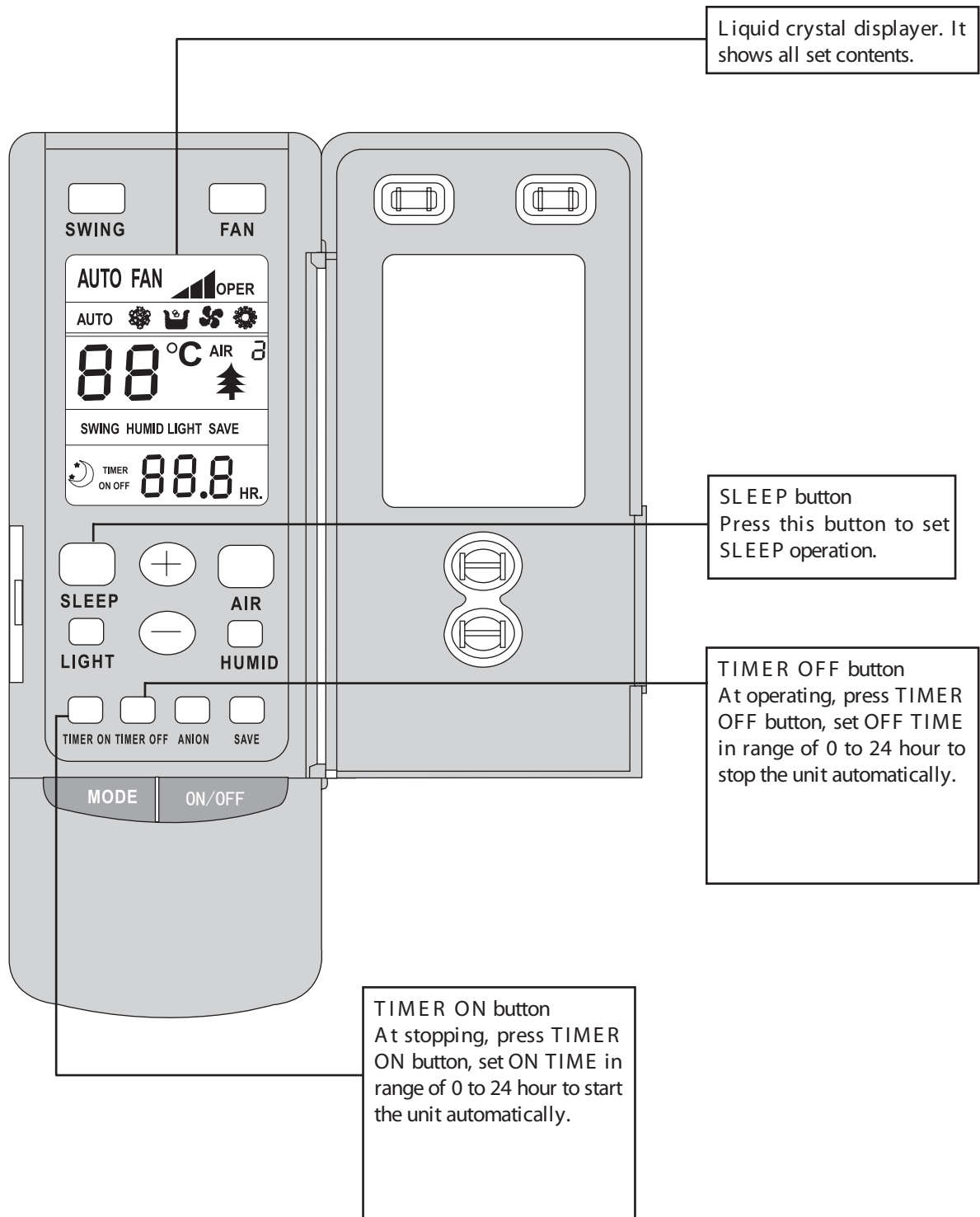

# Remote control operation procedure

## COOL mode operation procedure

- According to difference between room temp. and set temp., microcomputer can control cooling on or not.
- If room temp. is higher than set temp., compressor runs at COOL mode.
- If room temp. is lower than set temp., compressor stops and only indoor fan motor runs.
- Set TEMP. should be in range of 16°C to 30°C.

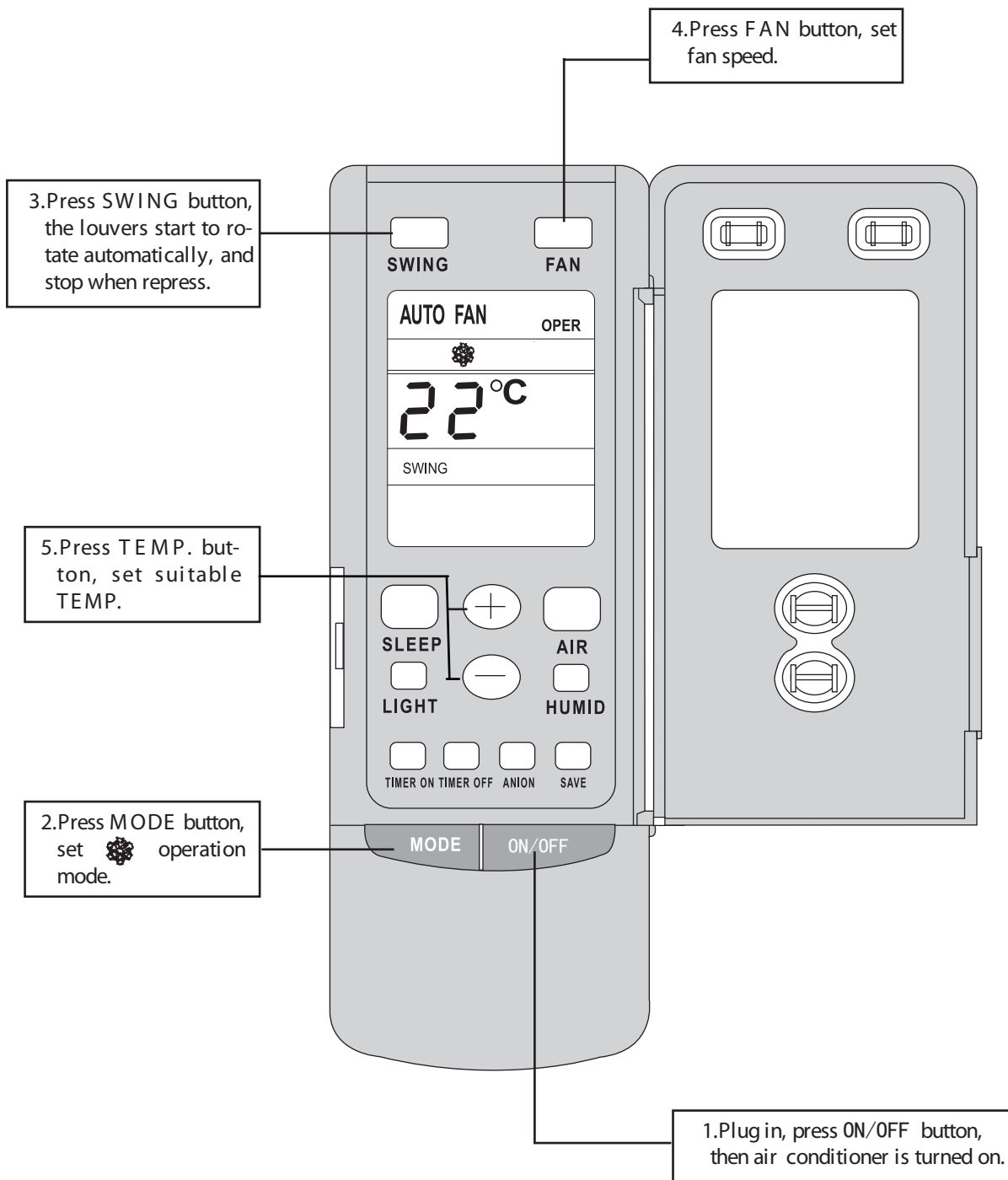

# Remote control operation procedure

## HEAT mode operation procedure

- If room temp. is lower than set temp., compressor runs at HEAT mode;
- If room temp. is higher than set temp., compressor and outdoor fan motor stop, only indoor fan motor runs.
- Set TEMP. should be in range of 16°C to 30°C .

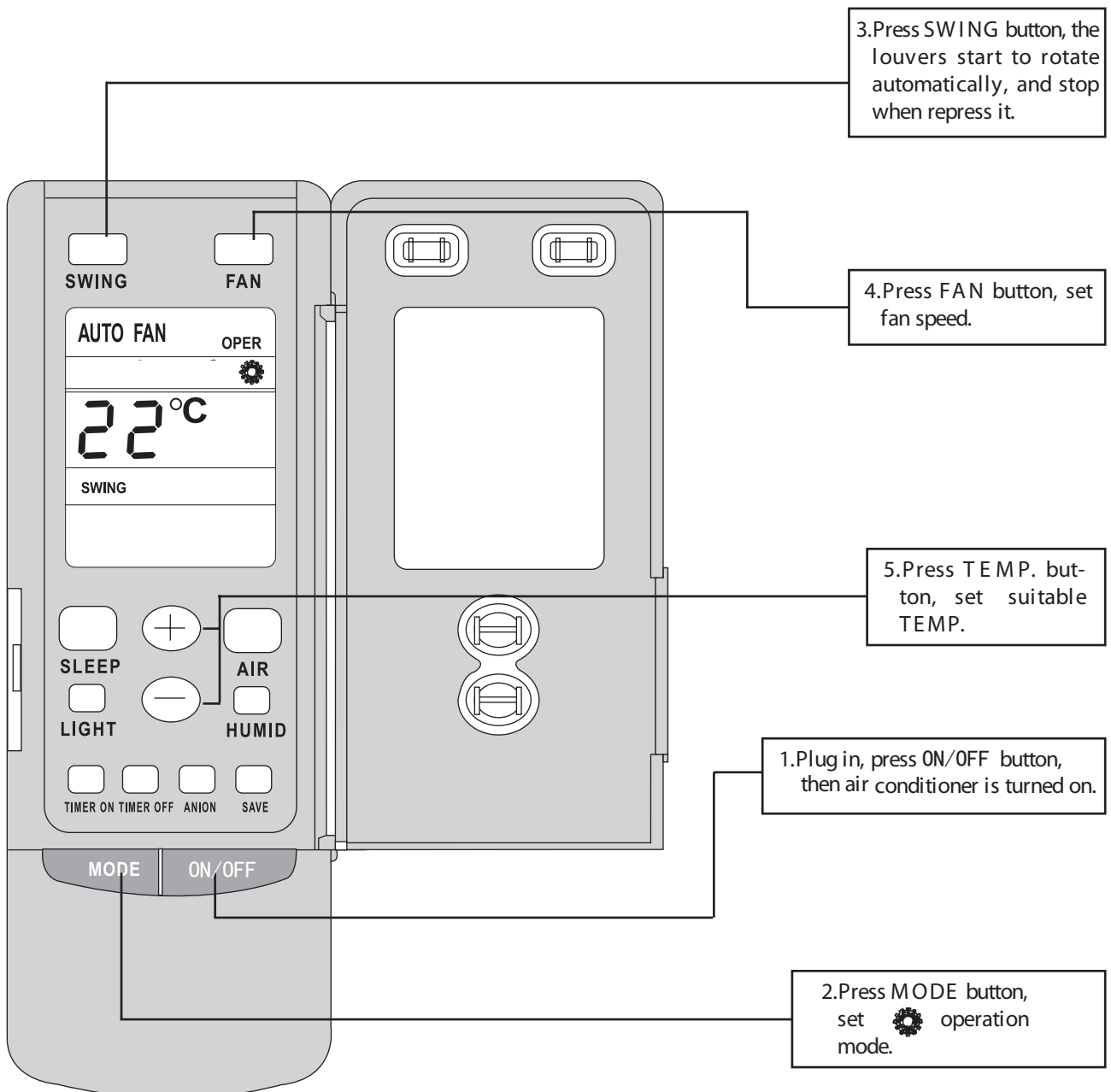

# Remote control operation procedure

## DRY mode operation procedure

- If room temp. is lower than set temp., compressor ,outdoor and indoor fan motor stop. If room temp. is between  $\pm 2^{\circ}\text{C}$  of set temp., Air conditioner is drying.If room temp. is higher than set temp.,unit operates at COOL mode.
- Set TEMP. should be in range of  $16^{\circ}\text{C}$  to  $30^{\circ}\text{C}$ .

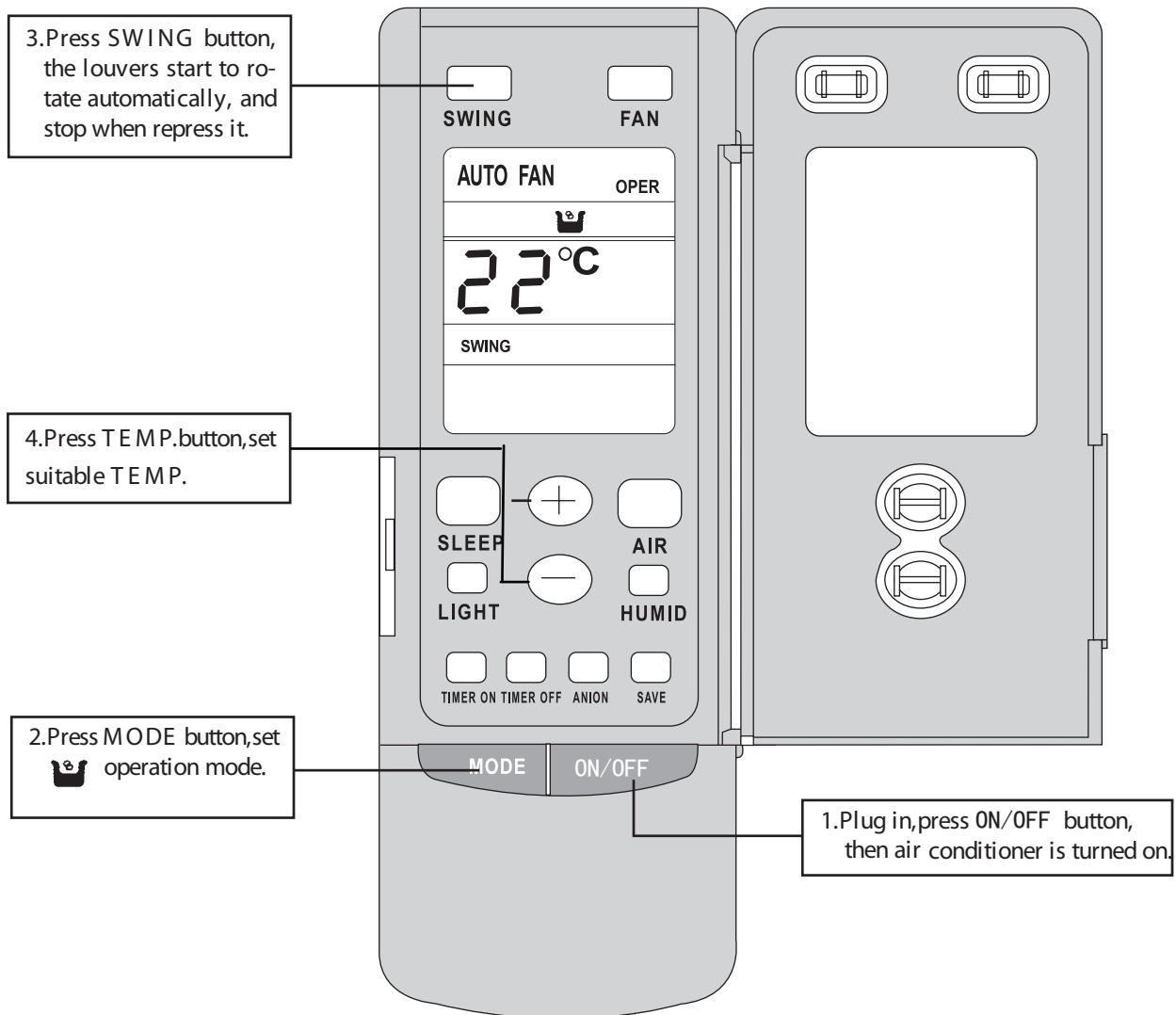

# Remote control operation procedure

## AUTO mode operation procedure

- At AUTO mode operation, standard TEMP. is 25°C for COOL mode and 20°C for HEAT mode.

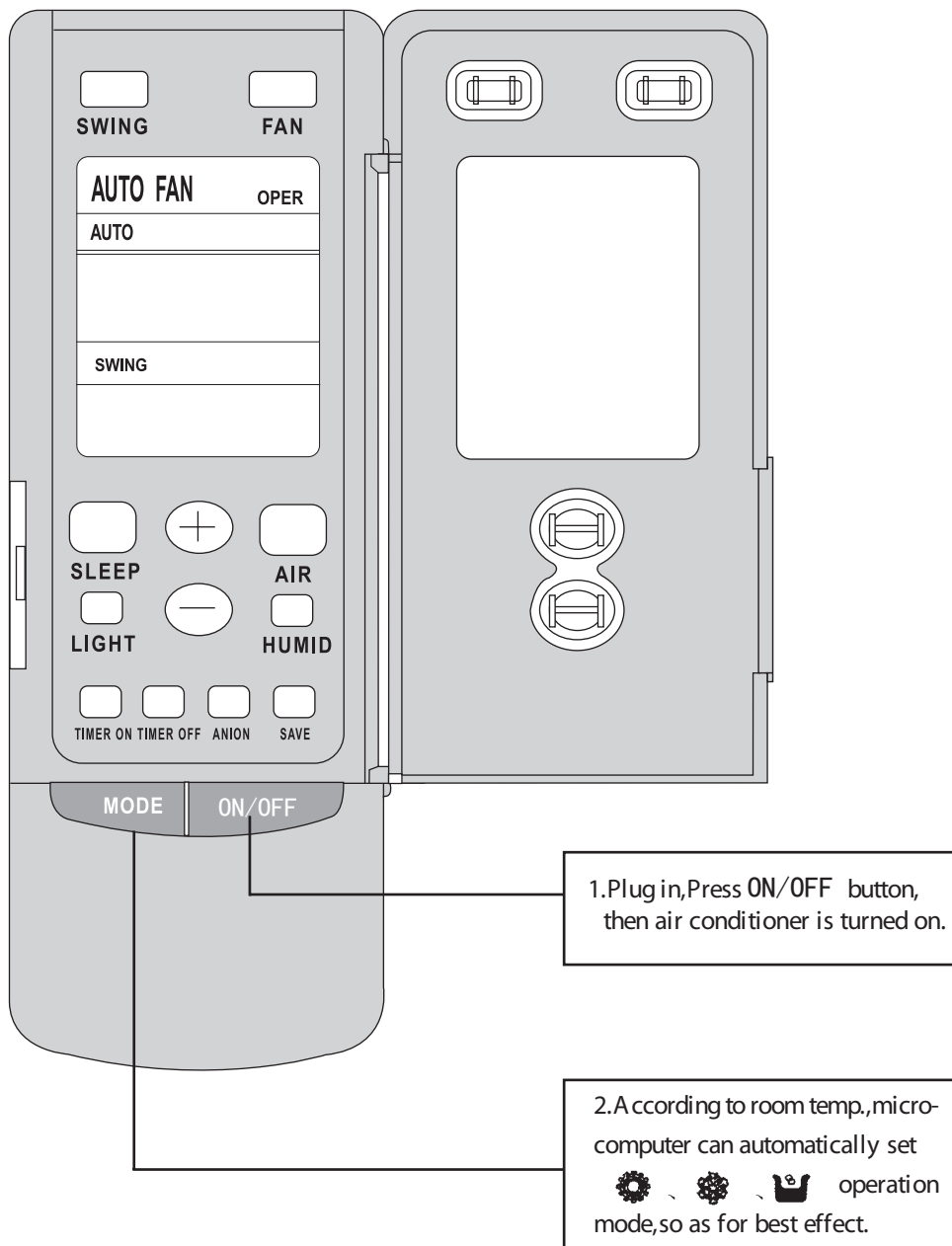

# Remote control operation procedure

## TIMER mode operation procedure

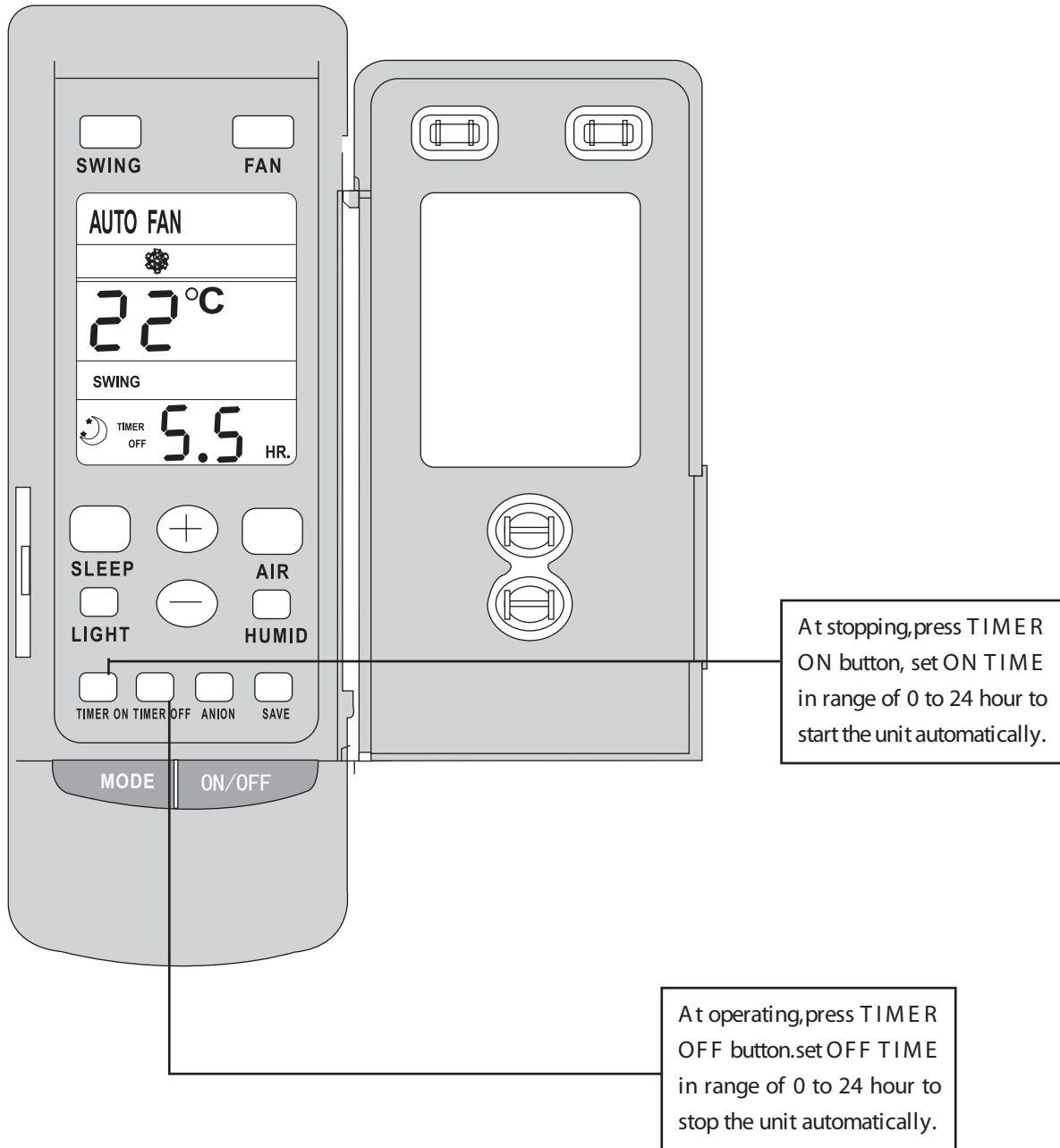

# Remote control operation procedure

## SLEEP mode operation procedure

- When the unit is cooling or drying, if SLEEP operation is set, TEMP. would increase 1°C in 1 hour and 2°C in 2 hours. Indoor fan motor runs at low speed.
- When the unit is heating, if SLEEP operation is set, TEMP. would decrease 1°C in 1 hour and 2°C in 2 hours. Indoor fan motor runs at low speed.

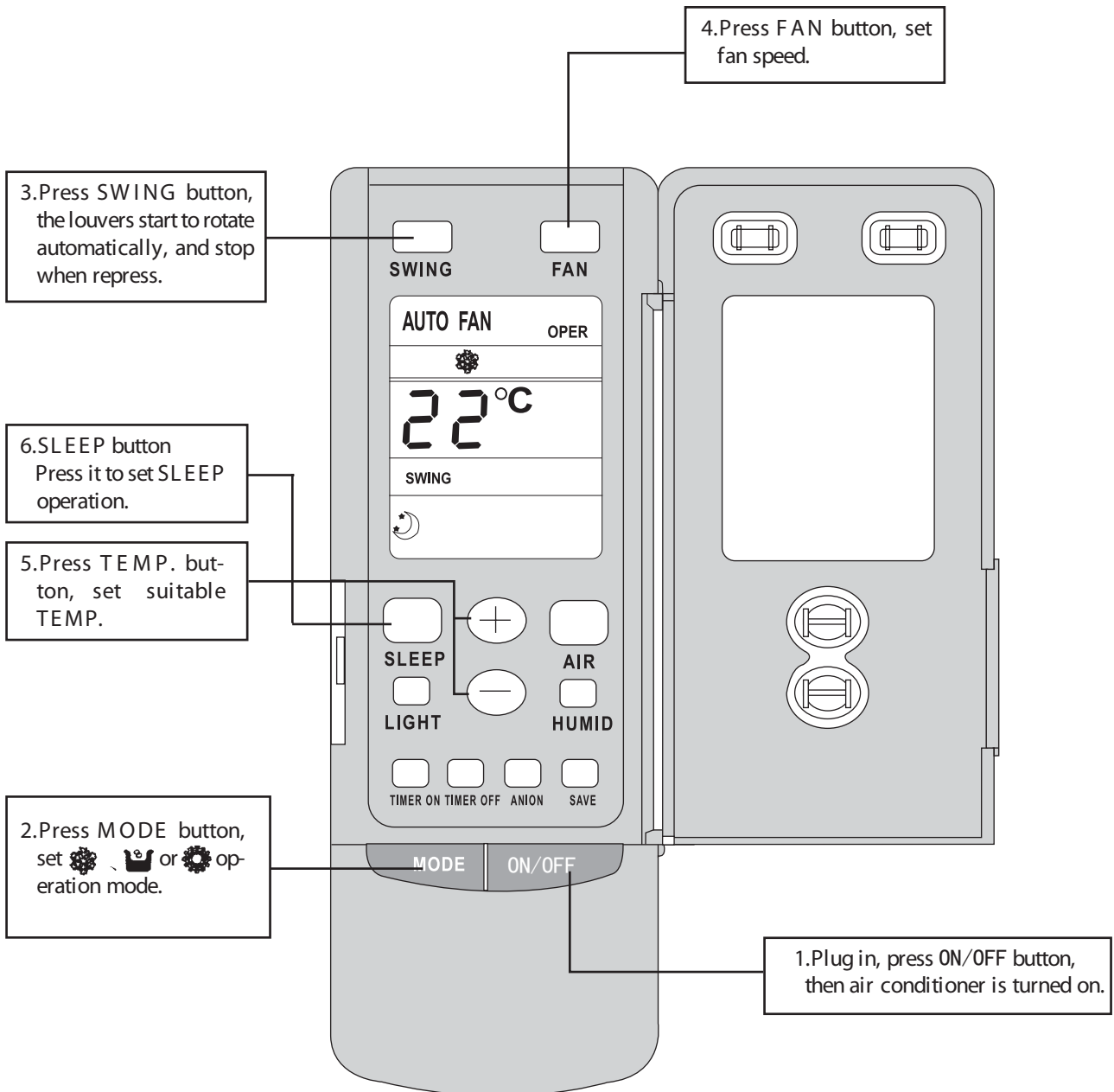

# Remote control operation procedure

## ● How to insert batteries

1. Remove the cover from the back of the remote control.
2. Insert the two batteries ( Two AAA dry - cell batteries ) and press ACL.
3. Re - attach the cover.

### Note:

- Don't confuse the new and worn or different types of batteries.
- Remove batteries when the remote control is not in use for a longtime.

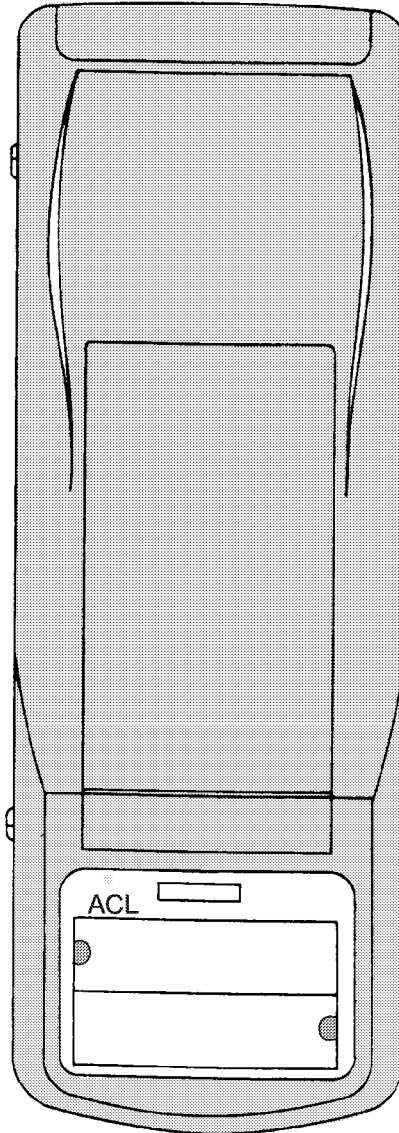

2 Insert the AAA dry-cell batteries.

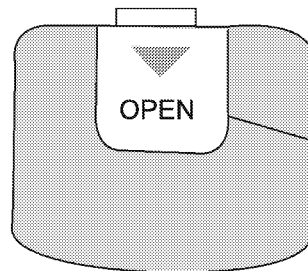
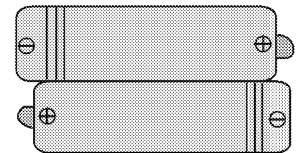

1 Remove the cover.  
3 Re - attach the cover.

# Optimum operation

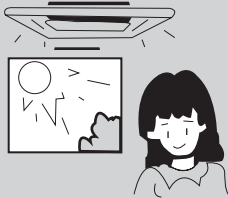
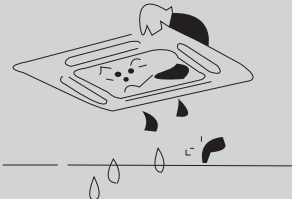
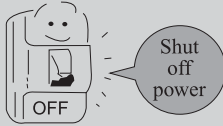
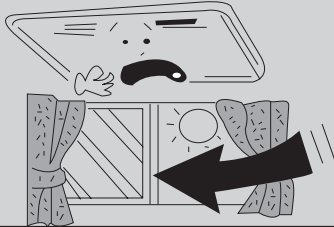
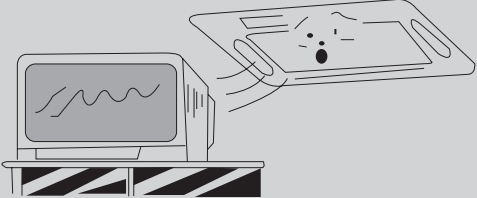
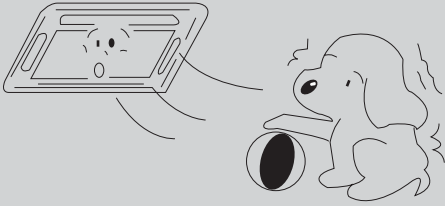
Adjust the room temperature properly	
Adjust the room temperature properly for a comfortable environment.	
Never place anything under the indoor unit that is to be kept dry.	
Water may drop from the indoor unit when the humidity is over 80% or when the drainage outlet is clogged.	
Turn off the main power supply switch when it is not to be used for long periods of time	
When the main power switch is turned on, some watts of electricity is being used even if the system is not operating. Turn off the main power supply switch to save energy.	
Do not open the doors and windows for a long time when air conditioner is operating	
Cooling and heating performance will be affected if the doors and windows are open for a long time.	
Place TV, radio, stereo, etc. at least 1m away from the indoor unit and the remote controller.	
It may cause interference in the picture or sound.	
Avoid direct air flow to pets and plants.	
It may do harm to them.	

# Trouble shooting

---

## ● Warning

- \* In case of something abnormal (such as bad smell), shut off the power switch immediately and contact service center.
- \* Do not repair the air conditioner by yourself. Because wrong repair may cause fire, please contact service center.
- \* the appliance should not be used by children without supervision.

## ● Check these items shown below before contacting service center.

Phenomenon	Cause	Corrective Measures
The system does not operate at all	Pause off or fuse broken	Change fause or replace fuse
	Power off	It will restart when power is on
	Loose plug	Put the plug into place
	Batteries of remote controller fall	Replace batteries
	Out of the remote controlling range	Keep distance in 8m or less
The system stops right after it is started	Object at the air intake and air outlet of the air conditioner	Remove them
Cooling and heating is melfunctioning	Object at the air intake and air outlet of indoor and out door units	Remove them
	Wrong temperature setting	Refer to p6
	Low fan speed	Refer to p6
	Air direction is not correct	Refer to p6
	Doors or windows are open	Close them
	Direct sunshine	Close the curtain or blinber
	Too many people in the room	
	Too many heating sources	
	Dirty air filter	Clean it

## ● Note:

If trouble still exists after checking the about items,please contact service center.

# Trouble shooting

## ● The following are not troubles

	“Trouble”	Cause
The unit does not operate when	Restart right after stopping	Once the unit is stopped, it will not operate for about 3 minutes to protect it
	Press SET TEMP. and then release immediately.	
	Power is switched on	Wait for 1 minute
Mist is emitted	When cooling	Room air is chilled rapidly and becomes foggy.
Outdoor unit is hot	after the unit is stopped	Compressor is emitting heat to get ready for restarting.
Noise	Buzz is heard at starting	It's the starting sound of thermostat and will turn low after 1 minute.
	Sound of running water can be heard during operation	This is caused by the refrigerant flowing inside the unit
	A “shuh” sound which is heard at the start or immediately after the stop of operation or which is heard at the start or immediately after the stop of defrosting operation.	This is the noise of refrigerant caused by flow stop and flow change. The noise is heard when the drainage pump is in operation.
	A continuous low “shah” sound is heard when the system is in cooling operation or at a stop.	
	Cracking noise can be heard during or after operation.	This is caused by the panel expanding or contracting due to the change in temperature.
Dust from the units	Starting operation after not using for a long time.	Dust absorbed by the unit blows out
Wind from the outlet smells	During operation	This is caused by the odors in the room which have gotten onto the air conditioner

# Installation notes

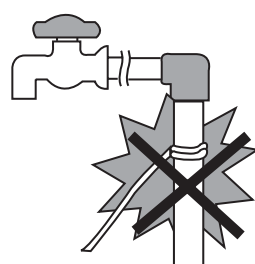
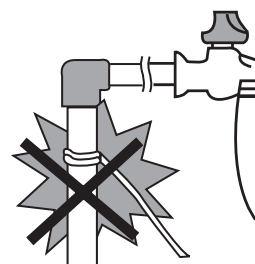
Location	Noise				
<ul style="list-style-type: none"> <li>• The air conditioner must be firmly installed and 3~4 liability checks must be done every year.</li> <li>• Avoid place within easy reach of young children.</li> <li>• Avoid other heat sources or direct sun light.</li> <li>• Install indoor unit away from TV set or radio.</li> <li>• Avoid where inflammable gas is likely to leak.</li> <li>• At salty coastal areas or special areas such as the vicinity of a sulphurous hot spring, please contact dealer before installation to make sure it is safe to use the unit.</li> <li>• Not to be installed in laundries.</li> <li>• The air conditioner must be positioned so that the plug is accessible</li> </ul>	<ul style="list-style-type: none"> <li>• Select a place with good ventilation or it may affect performance or increase noise.</li> <li>• Install the air conditioner on a foundation that can withstand its weight. Insufficient strength may result in the fall of equipment and cause injury.</li> <li>• Select a place so as not to annoy neighbor with the hot air or noise.</li> <li>• Never place objects near the air outlet or the unit, it may affect performance or increase noise.</li> <li>• If there is abnormal noise during the operating, contact dealer immediately.</li> </ul>				
Installation and transportation	Wiring arrangement				
<ul style="list-style-type: none"> <li>• Installation and transportation of the unit must be done by skilled personnel.</li> <li>• Be sure to use only the specified accessories and parts for installation, failure to use may lead to electric shock, leakage or fire.</li> <li>• Carry out installation with consideration of strong winds, typhoons, or earthquakes. Improper installation work may result in accidents due to fall of equipment.</li> <li>• If the unit is to be moved to other place, please consult dealer first.</li> <li>• The suction grille must be opened by skilled personnel.</li> </ul>	<ul style="list-style-type: none"> <li>• Make sure wiring is carried out by qualified personnel according to laws and regulations and this manual, using a separate circuit and suitable fuse.</li> <li>• Be sure to install an earth leakage breaker.</li> <li>• Diameter of power supply cord must be big enough. (Refer to P24 about the sizes of diameter)</li> <li>• If the supply cord is damaged, it must be replaced by the manufacturer or its service agent or a similarly qualified person in order to avoid a hazard.</li> <li>• The appliance shall be installed in accordance with relative wiring regulations.</li> </ul>				
<p><b>Earthing requirement</b></p> <ol style="list-style-type: none"> <li>1. Air-conditioner is the class I appliance, it must be use the suitable earthing connection.</li> <li>2. Please do not cut or change the method of use of the yellow / green earthing wire of the air-conditioner. Otherwise, it may cause the electrical leakage.</li> <li>3. Earthing resistance should be approved by Country Standard GB 17790.</li> <li>4. User power should be provided a reliable earthing terminal. Please do not let the earthing wire to connect the following place:             <table border="0" data-bbox="478 1485 1356 1561"> <tr> <td>1. Water supply</td> <td>3. Sewage tube</td> </tr> <tr> <td>2. Gas supply</td> <td>4. Some places there are not reliable by a professional.</td> </tr> </table> </li> </ol>		1. Water supply	3. Sewage tube	2. Gas supply	4. Some places there are not reliable by a professional.
1. Water supply	3. Sewage tube				
2. Gas supply	4. Some places there are not reliable by a professional.				
<p><b>Water pipe</b></p> <p>Some parts of the water pipe are made of plastic materials and not suitable for earthing.</p> 	<p><b>Gas pipe</b></p> <p>If there is electrical leakage accidentally from air conditioner, it is easy to cause fire or explosion.</p> 				

# Care and maintenance

Please pull out the power plug after you used the air conditioner.

## Warning

■ Pull out the power plug before cleaning

■ Do not splash water directly to the unit

## How to clean the air filter

### 1. Open the suction grille

Use screwdriver screws the two screws.  
Slide both knobs simultaneously as shown and then pull them downward slowly.

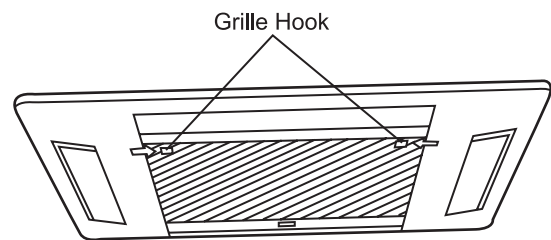

### 2. Remove the air filters.

Slide knobs on the back of the suction grille outward and remove the air filter.  
Then remove three air cleaners on it.

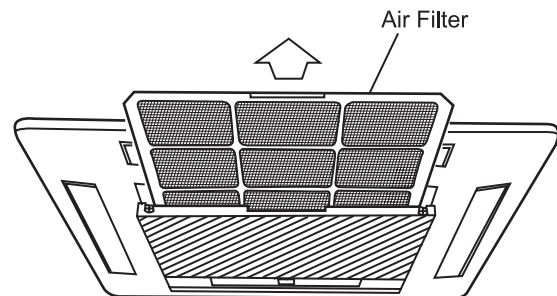

### 3. Clean the air filter

Use vacuum or wash the air filter with water when the air filter is very dirty, use neutral detergent and water. Let the filter dry naturally at shady place.

#### Note:

Do not clean with hot water

Do not dry over fire

Do not run the air conditioner without the air filter.

The suction grille must be opened by skilled personnel.

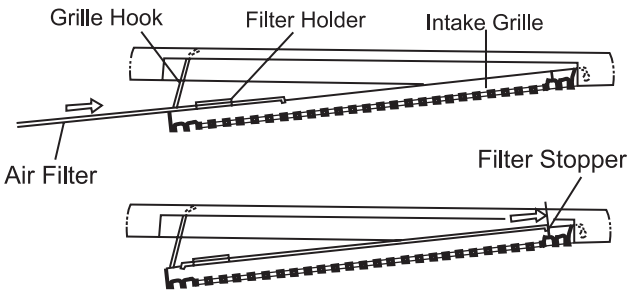

# Care and maintenance

<p>4. Fix the air filters</p> <ul style="list-style-type: none"> <li>• Replace the air filter into its holder.</li> <li>• Make sure that the air filter makes contact with the filter stopper when it is replaced into its holder.</li> </ul>	
<p>Shut the suction grille.</p>	<p>Refer to step 1.</p>

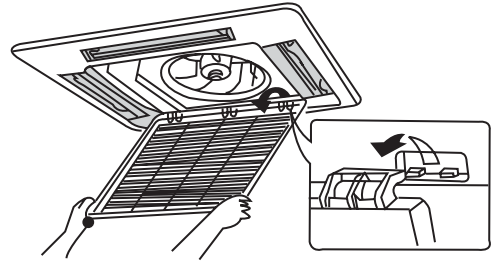
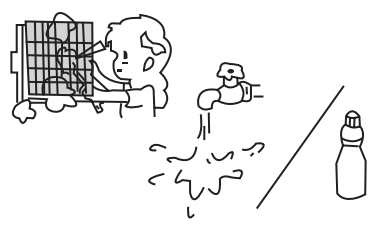
How to clean the suction grille	
<p>1. Open the suction grille.</p>	<p>See step 1 of “How to clean the air filter”</p>
<p>2. Remove the air filters.</p>	<p>See step 2 of “How to clean the air filter”</p>
<p>3. Remove the suction grille Open the suction grille at 45° and then lift.</p>	
<p>4. Wash with water. When the suction grille is very dirty, use soft brush and neutral detergent. Shake off water and dry in a shady place. Notes: Do not wash with hot water.</p>	
<p>5. Fix the suction grille</p>	<p>Refer to step 3.</p>
<p>6. Fix the air filter.</p>	<p>See step 4 of “How to clean the air filter”</p>
<p>7. Close the suction grille</p>	<p>Refer to step 1.</p>

# Care and maintenance

## Before starting the air conditioner for the first time in the season

1. Check to make sure no objects obstructing the intake and outlets parts on both the indoor and outdoor units.
2. Check to make sure ground wire is connected and that it is not damaged.
3. Check to make sure air filter has been cleaned.
4. Turn on the power 6 hours before starting the air conditioner.

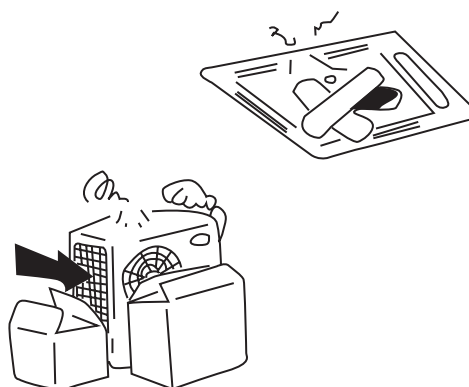

## End of season cleaning

1. Clean the filter and the body of the unit.
2. Turn off power.
3. Clear outdoor unit of dust.
4. If there is any rust in the outdoor unit, this should be painted over to prevent the rust from spreading.

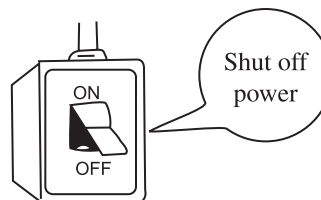

# Care and maintenance

---

## ● Power supply and wiring requirement

1. Power frequency of air-conditioner should be 50Hz, voltage:

AC 230V±10%

If voltage are over may cause the parts of electric equipment damaged. If the voltage are too low may cause shake on compressor, it may let the cooling system damaged, and also, the compressor and parts will not work. Voltage should be stable, which cannot have a big fluctuation.

2. User power supply should be provided a reliable earthing connect. (see earth requirement)

3. Watt requires are large in air conditioner, power supply cord of air conditioner should be under the following requirement:

1. Special circuit for air conditioner

2. The capacity should be at least 1.5 times of maximum current, wire cross section (the cross section area) should be use the maximum value.

3. Including an electric leakage protection with enough capacity.

4. Including an air switch with suitable capacity, please note the following table. Air switch should be included magnet buckle and heating buckle function, it can protect the circuit-short and overload. (Caution: please do not use the fuse only for protect the circuit)

Air-conditioner (W)	Air switch capacity
5000	16A
3500	16A

## ● Electric connection requirement

1. Should have a reliable earth connection (see earth connection requirement)

2. Screw of wire should be tight, damaged screw should be changed. Self-tapping screw cannot use on electric connection.)

3. Wire should be used by the provided one. Please do not change the wire, length and the end of it. If you need to adjust, please contact with the local SINCLAIR service center.

4. Please do not connect the plug with the non-plug wire by yourself.

5. Indoor and outdoor electrical connecting wire should not affect by elasticity and twist.

# Care and maintenance

---

## ● Circuit Diagram

The under mentioned - Electric wiring

## ● Caution

1. Please check the earth connection before running test.
2. Voltage should be following the requirement. The voltage should not be too big after the running test (normally, 9000BTU unit not over 15V, 18000BTU unit not over 10V, 28000BTU unit not over 5V).
3. Electric meter should have enough current, watt capacity.

## ● Other requirement

1. Installation of air conditioner must be far away from combustibles, for instance, window curtains and cloths. The air-outlet and air-inlet of Air conditioner with heating by electricity must not block by combustibles, eg. window curtains and cloths.
2. Please avoid to use the octopus type socket, movable socket for connect.
3. Please turn off the unit if it will not use in a long time. Remove the plug or turn off the units is a safe method.
4. Air conditioner will according to your requirement to auto switch on or off. Please do not usually turn on or off the air conditioner, it will affect the disadvantage of the air conditioner.
5. Please do not install the unit in the place with combustibles, corrosive and with a big magnetic fields affect.
6. Please contact the retailer before using the air conditioner in the place which is close to the coast with high salty area or close to hot spring with sulfur gas area.
7. This product must not be disposed together with the domestic waste. This product has to be disposed at an authorized place for recycling of electrical and electronic appliances.



# Technical specifications

## Technical specifications

Model	ASC-12A	ASC-18A
F functions	Cooling/heating	Cooling/heating
Cooling capacity(w)	3500	5000
Heating capacity(w)	4150	5500
R rated voltage and frequency	230V ~50Hz	220-230V ~50Hz
Cooling/Heating Input current(A)	5.36/5.51	10/9.5
Maximum Current input(A)	8.23	15
Cooling/Heating Rated power(kW)	1.58/1.56	2.0/2.1
Recycling air volume(m <sup>3</sup> /h)	680	680
Refrigerant And weight(K g)	R410A 1.3	R410A 2.0
Waterproof level		IPX 4
Noise(indoor/outdoor)(dB(A))	44/54	47/59
Climate		T1
Anti-electric shock protection		I
Weight (kg) (main unit/panel/outdoor)	20/5/44	20/5/65
Dimension(cm) (width * height * depth)	Main unit:60x60x23 Panel:65x65x5 Outdoor:84.8X 54X 32	Main unit:60x60x23 Panel:65x65x5 Outdoor:95X 70X 41.2

















\* Data listed above may be changed without informing the consumers;

\* Please see the nameplate for actual data;

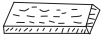
\* Fuse: T200mAL(250V), T3.15AL(250V).

# Installation accessories and drawings

## ● Accessories

No.	Name	Shape	Quantity		Notes
1	Drainage hose		1		For indoor side pipe joint
2	Clamp		1		For hole
3	Nylon fastener		4	L=200	
4	Washer		10	10	
5	Paper pad for installaiton		1		
6	Screws		4	ST4.8 × 13-F	Use for Paper pad for installation
7	Heat preservation Sponge for pipe		2		Encase the tie-in
8	Big sealing pad		1	5 × 160 × 300	
9	Sealing pad		1	5 × 45 × 300	
10	Small sealing pad		2	3 × 30 × 150	
11	Sealing bar		1	120 × 65 × 25	
12	PVC tape		2	30 × 10	
13	Screws		8	ST4.2 × 9.5PA	
14	Remote controller		1		For mounting the remote control unit
15	Battery		2	AAA 1.5V	For remote control unit
16	Signal control wire		2		
17	Power supply wire		1		
			1		

# Installation drawings

## ● Installation drawings

### Indoor unit

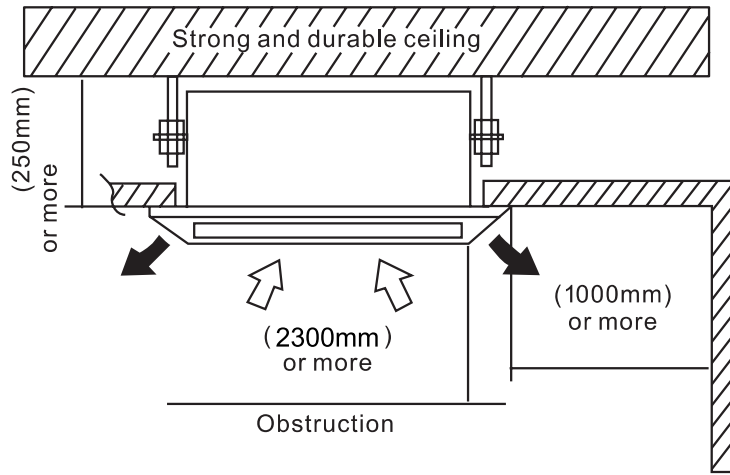

(Fig.1)

### Outdoor unit

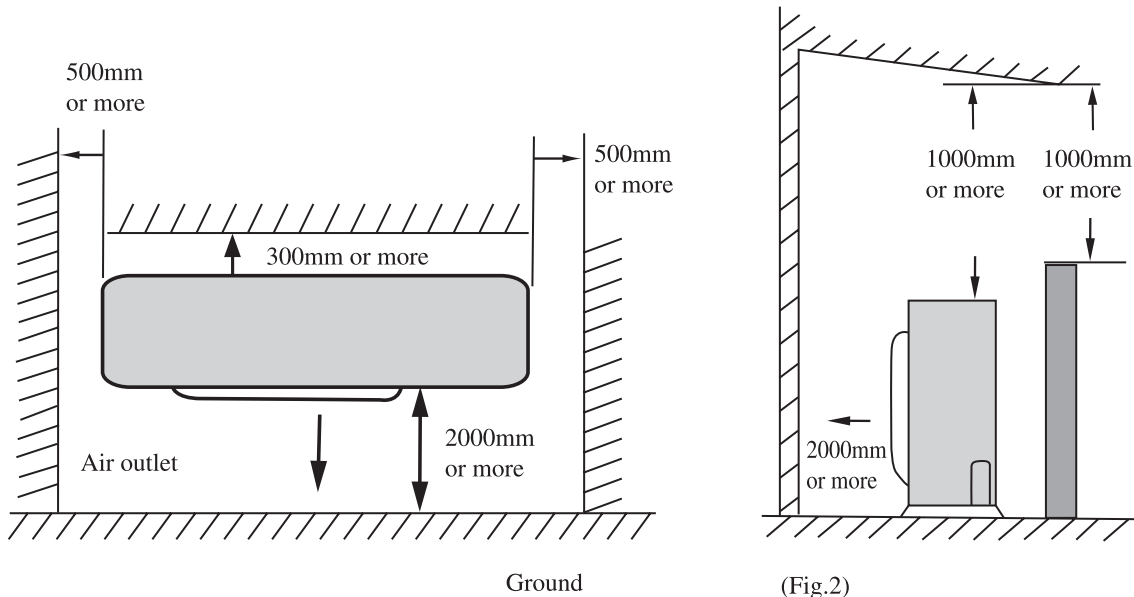

(Fig.2)

## ● Note:

Air conditioner must be installed by skilled personnel according to this manual.

# Indoor unit installation

## ● Location

1. Do not place object near the air outlet so that conditioned air can reach the whole room.
2. Be sure to install the indoor unit firmly and horizontally.
3. Select the place that can support 4 times of the indoor unit's weight and will not increase noise and vibration.
4. Select a place easy to drain water and connect with the outdoor unit.
5. Make sure there is enough space for maintenance and make sure the distance between the unit and ground is 1.8m or more.
6. Make sure the suspension bolt pitch can hold 4 times of the indoor units's weight, otherwise, you should strengthen the suspension bolt pitch.

## ● Note:

1. Keep enough distance from the kitchen.
2. The appliance shall not installed in the lundry

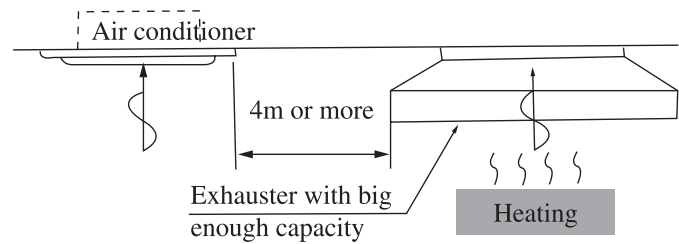

## ● Ceiling opening and suspension bolt (M10) pitch demension.

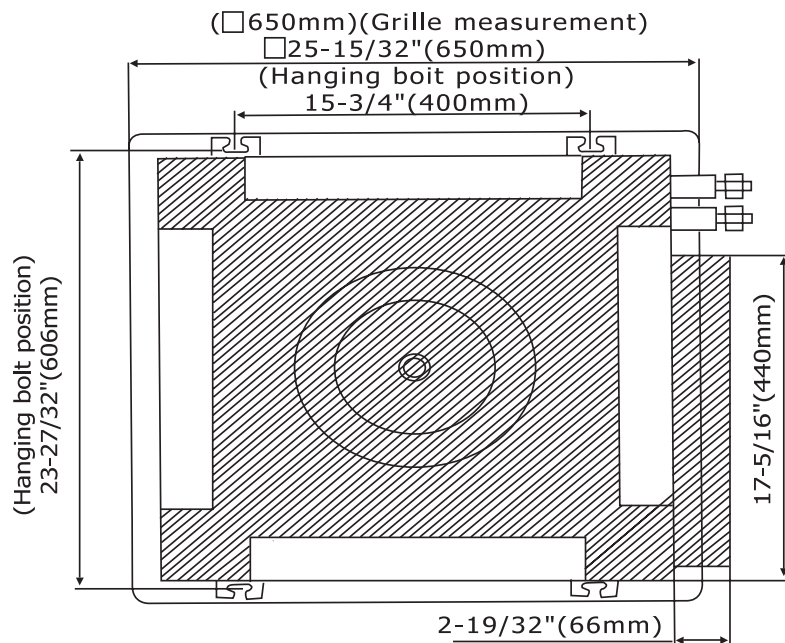

## ● Hanging preparations

Firmly fasten the hanging bolts as shown in Fig.4 or by another method.

Fig.4

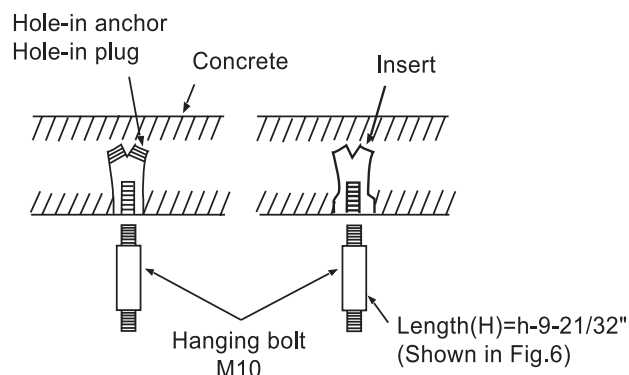

# Indoor unit installation

Fig.5

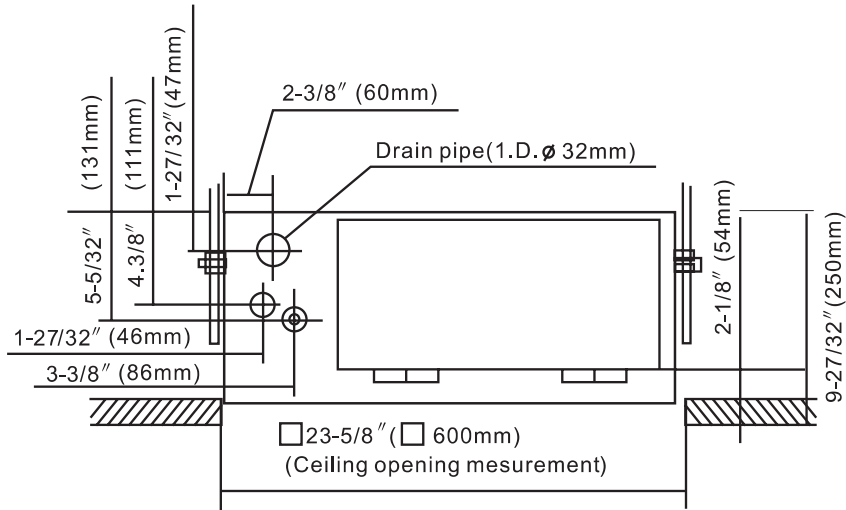

## ● Hanging preparations

- (1) Install special nut A, then special nut B onto the hanging bolt. (Fig.6)
- (2) Raise the body and mount its hooks onto the hanging bolt between the special nuts. (Fig.6)
- (3) Turn special nut B to adjust the height of the body. (Fig.6)
- (4) Leveling a level, or vinyl hose filled with water, fine adjust so that the body is level.

## Warning

**Perform final tightening by tightening the double nut firmly.**

Fig.6

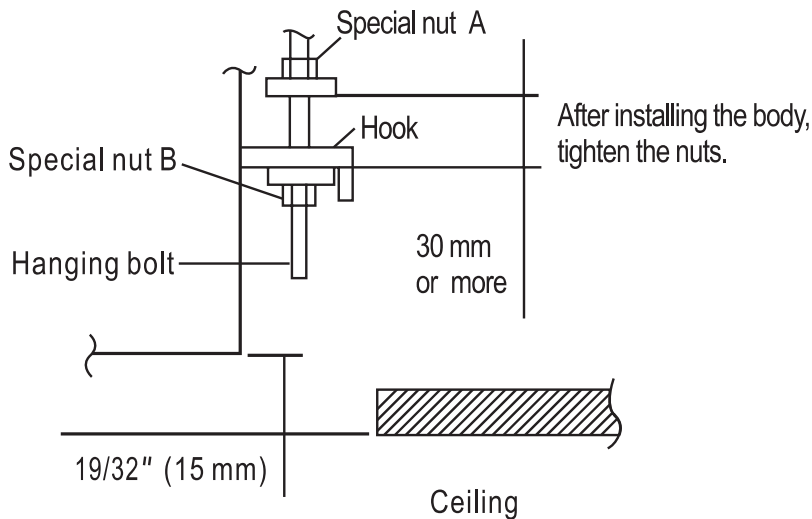

# Indoor unit installation

Fig.7

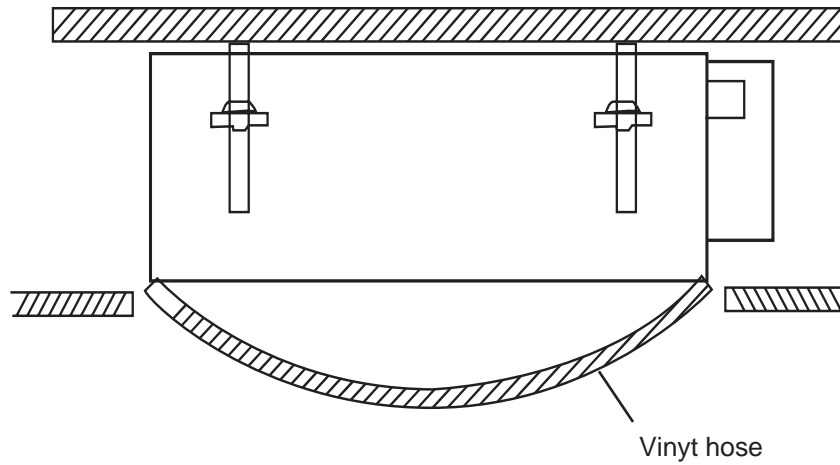

## ● Installing drain pipe

**NOTE: Install the drain pipe.**

- Install be drain pipe with downward gradient (1/50 to 1/100) and so there are no rises or traps in the pipe.
- Use general hard polyvinyl chloride pipe (VP25) [outside diameter 1-1/4" (32mm)] and connect it with adhesive (polyvinyl chloride) so that there is no leakage.
- When the pipe is long, install supporters.
- Always heat insulate the indoor side of the drain pipe.
- When desiring a high drain pipe height, raise it up to 15" (400 mm) or less from the ceiling within a range of 6" (150mm) from the body. Arise dimension over this range will cause leakage.

Fig.8

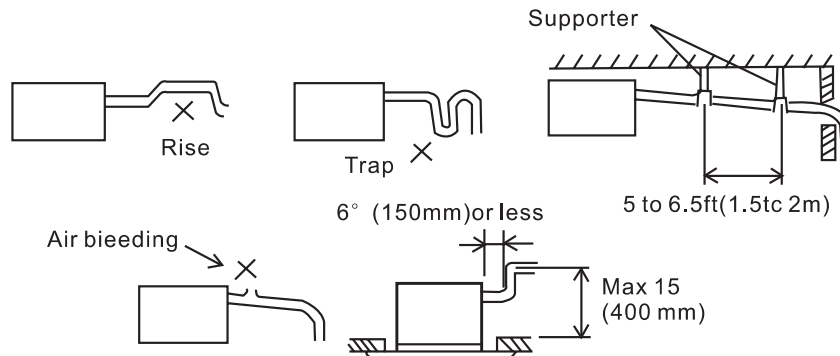

# Indoor unit installation

## ● Connecting the pipes

- Besure to use both a spanner and wrench together as shown in the drawing during connecting or disconnecting pipes to/from the unit.
- The pipe of water-in/out is pipe thread G3/4. The surface of thread should be enlaced by the two or three-circles trap.
- After the water-in pipe and water-out pipe is connecting tightly, starting the water pump, then checking it's airproof performance.
- Insulate it as shown in the drawing below.
- Use sealing pad (10) to wrap the water-in/out pipe and the insulation (8).

Fig.9

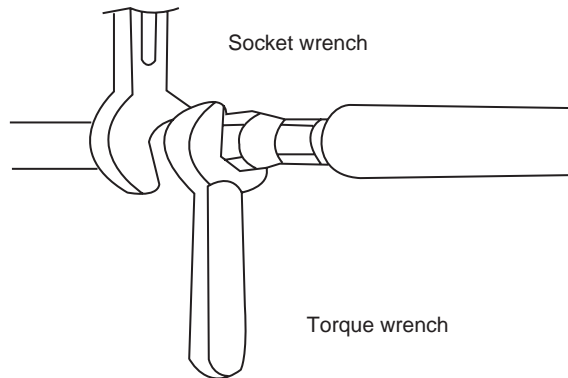
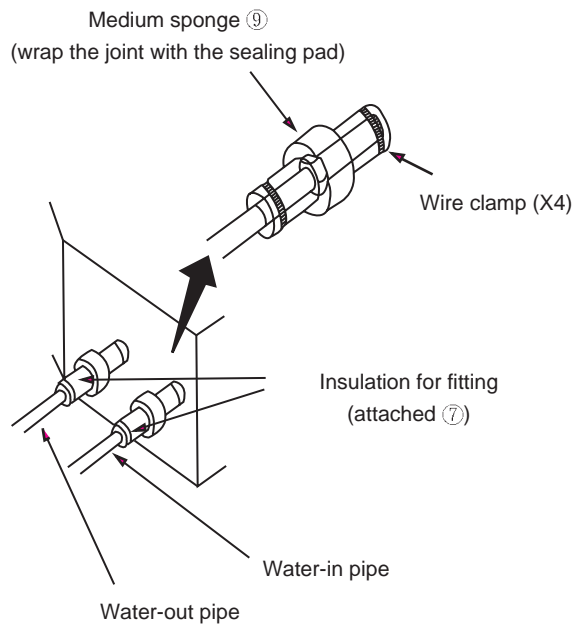

Fig.10



# Indoor unit installation

## ● Electrical wiring

### How to connect wiring to the terminals

#### A. For solid core wiring (or F-cable)

- (1) Cut the wire end with a wire cutter or wire-cutting pliers, then strip the insulation to about 15/16" (25mm) of expose the solid wire.
- (2) Using a screwdriver, remove the terminal screw (s) on the terminal board.
- (3) Using pliers, bend the solid wire to form a loop suitable for the terminal screw.
- (4) Shape the loop wire properly, place it on the terminal board and tighten securely with the terminal screw using a screw driver.

#### B. For strand wiring

- (1) Cut the wire end with a wire cutter or wire-cutting pliers, then strip the insulation to about 3/8" (10mm) of expose the solid wire.
- (2) Using a screwdriver, remove the terminal screw (s) on the terminal board.
- (3) Using a round terminal fastener or pliers, securely clamp a round terminal to each stripped wire end.
- (4) Position the round terminal wire, and replace and tighten the terminal screw using a screwdriver.

#### C. Attention:

An all-pole disconnection switch having a contact separation of at least 3mm in all poles should be connected in fixed wiring.

Fig.11

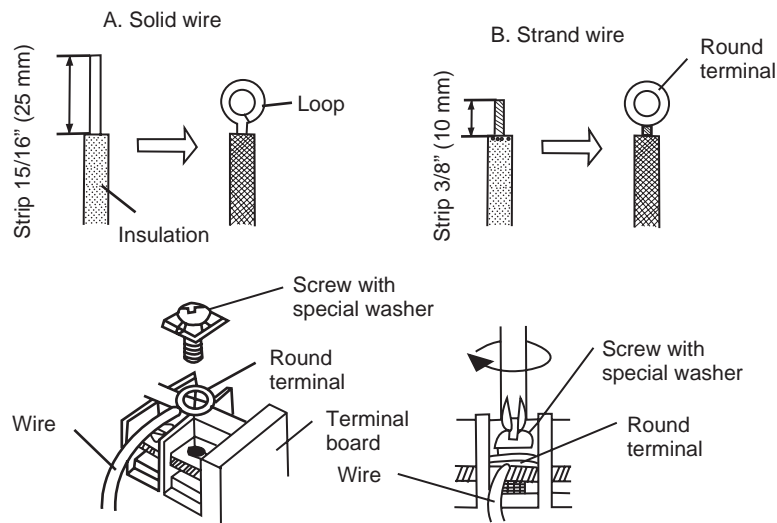

# Indoor unit installation

## ● Indoor unit side

Remove the control box cover and install the connection cord. (Fig. 12 and 13)

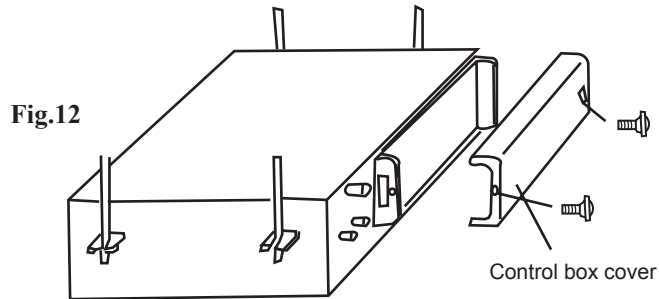

## ● Note

- \* The temperature of refrigerant circuit will be high, please keep the interconnection cable away from the copper tube.
- \* An all-pole disconnection device which has at least 3mm separation distance in all pole and a residual current device(RCD)with the rating of above 10mA shall be incorporated in the fixed wiring according to the national rule.

Fig.13

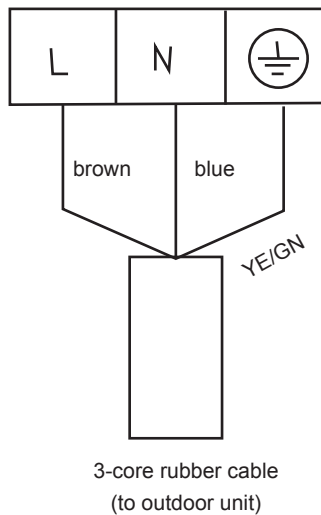

# Indoor unit installation

## ● Bolting the grille assembly to the body

Install the grille assembly to the body with the four bolts, spring washers, and washers.

Fig.16

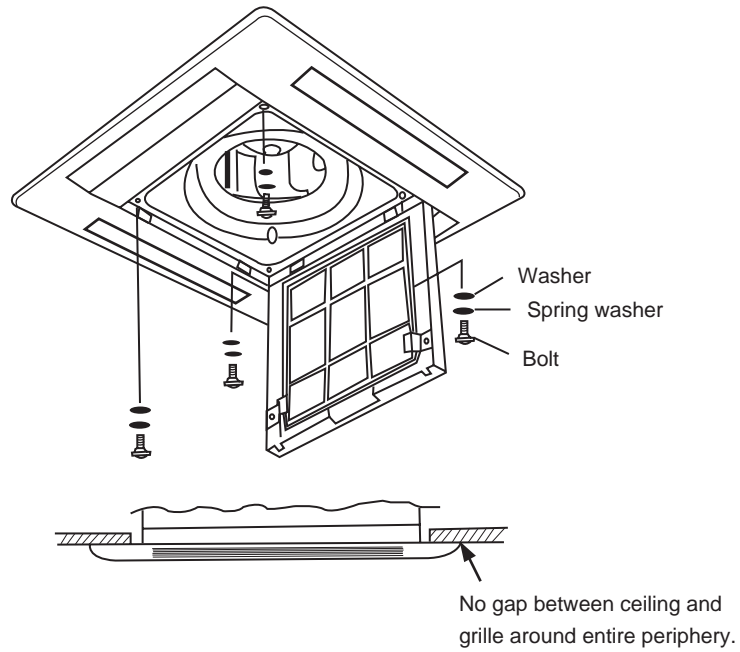

## Wireless unit connection wire wiring

- (1). Connect the connector in accordance part A detail view.
- (2). Then clamp the lead wire with clamp so that it does not touch the rotating parts.

Fig.17

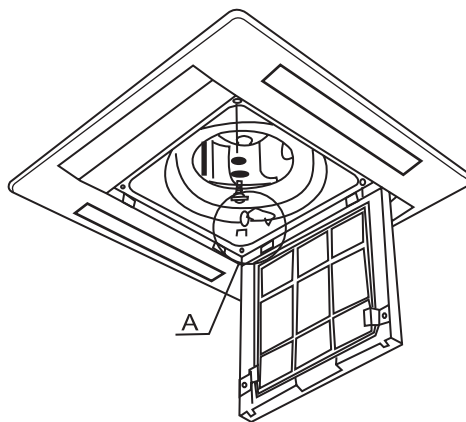

# Indoor unit installation

**Fig.18** Part A detail view

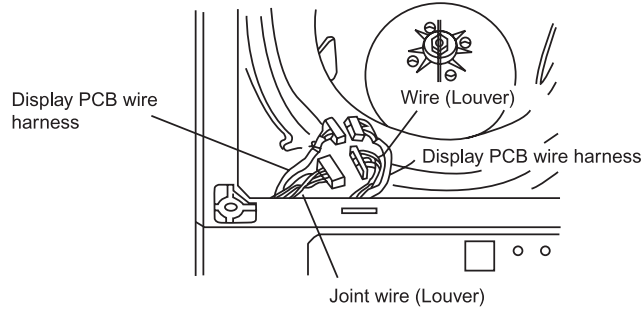

## Installing/Removing the intake grille

### 1. Installing the intake grille

- (1) Full insert the intake grille hooks into the rectangular holes in the panel.

**Fig.19**

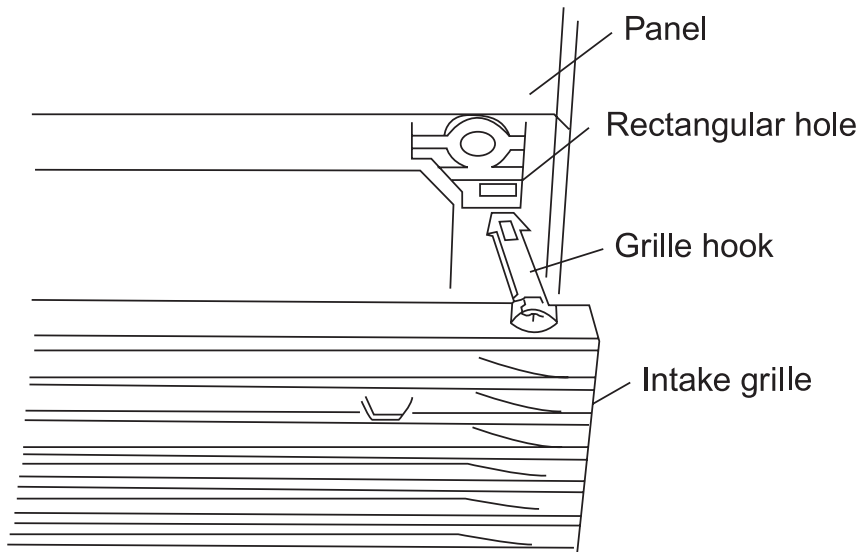

- (2) Close the intake grille, then slide the tow grille stoppers outward.

**Fig.20**

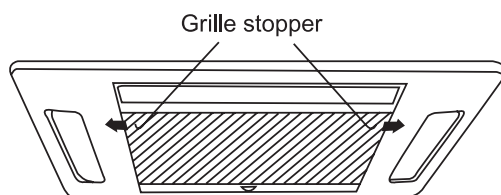

# Indoor unit installation

## 2.Removing the intake grille

(1) Slide the two grille stoppers inward, and then open the intake grill.

Fig.21

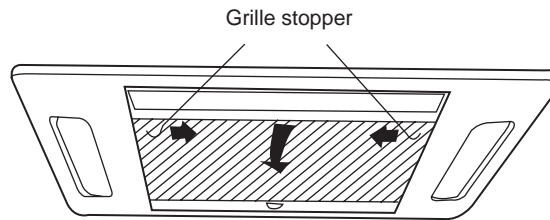

(2) Remove the grille hook screws, and then open the intake grille.

Fig.22

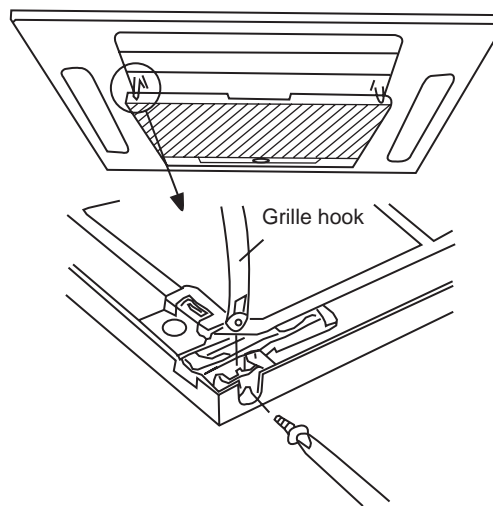

(3) Open the intake grille so that it is at an angle of 20° to 40° ,and then remove the grille.

Fig.23

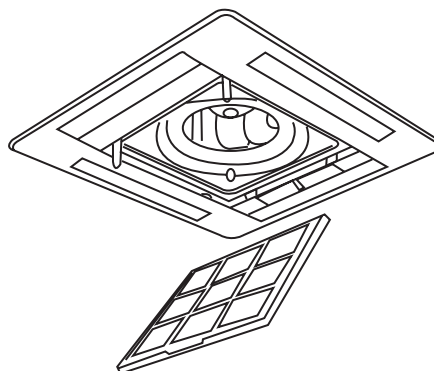

### Caution:

- (1) the louver angle cannot be changed if the power is not on, (It moved by hand, it may be damaged.)
- (2) The grille assembly is directional relative to the air conditioner body.
- (3) Install so that there is no gap between the grille assembly and the air conditioner body.

# Indoor unit installation

## ● Connection of refrigerant pipe

- Be sure to use both a spanner and torque wrench together as shown in the drawing, connecting or disconnecting pipes to/from the unit.
- Refer to table 1 to determine the proper tightening torque (over tightening may damage the flare and cause leaks.)
- When connecting the flare nut, coat the flare both inside and outside with refrigerating machine oil and initially tighten by hand 3 or 4 turns.
- Check the pipe connector for gas leaks, then insulate it as shown in the drawing below.
- Use sealing pad (11) to wrap joint between gas pipe and the insulation (8).
- The enclosure of the appliance shall be marked by word, or by symbols, with the direction of the fluid flow.

Coat here with refrigerating machine oil

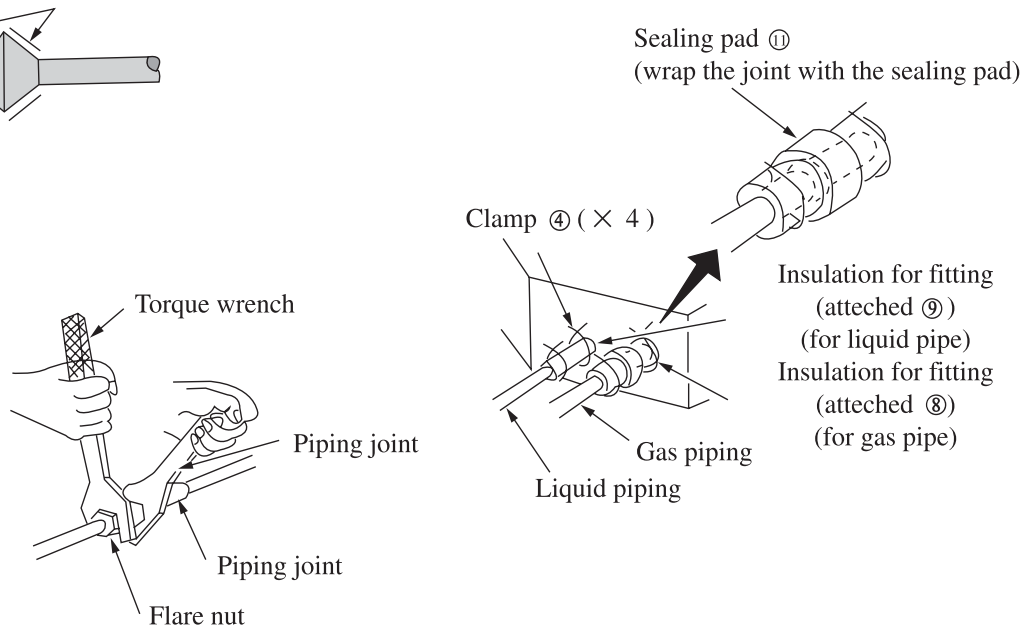
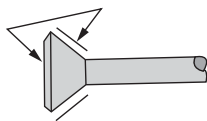

● Table 1

Pipe gauge	Tightening torque	Notes
Φ 9.52	30~40N.m	Add 30g
Φ 16	60~65N.m	
Φ 6	15 ~ 20N.m	
Φ 12	50 ~ 55N.m	

The maximum length for refrigerant piping is 20 meters, when the length exceeds 10 meters, you should charge additional (refrigerant as shown in following for per-meter added).

# Outdoor unit installation

## Selecting installation site

- Select an installation site where the following conditions are satisfied and that meets with your customer's approval.
- Places which are well-ventilated.
- Safe places which can withstand the unit's weight and vibration and where the unit can be installed level.
- Places where the unit does not bother next-door neighbors.
- Places where there is no possibility of flammable gas leak.
- Places where things distressed in water do not exist because water drains off the outdoor unit.
- Places where servicing space can be well ensured.
- Places where strong wind can not blow directly to outdoor unit.

## Outdoor unit installation

1. Install the unit firmly with combination of M10 or more bolts and nuts on the foundation that can fully support the weight of the unit and make sure the unit stand vertically.
2. Do not install the unit on the top of building.
3. If there is noise caused by vibration add rubber between the unit and the foundation, Please.
4. When the air conditioner is heating or defrosting, drain water of the outdoor unit to an appropriate place with the drain hose.
5. Fixing method: Fix the outdoor drainage hose head in the hole of the chassis, then connect the drainage hose with the mouth of drainage pipe.

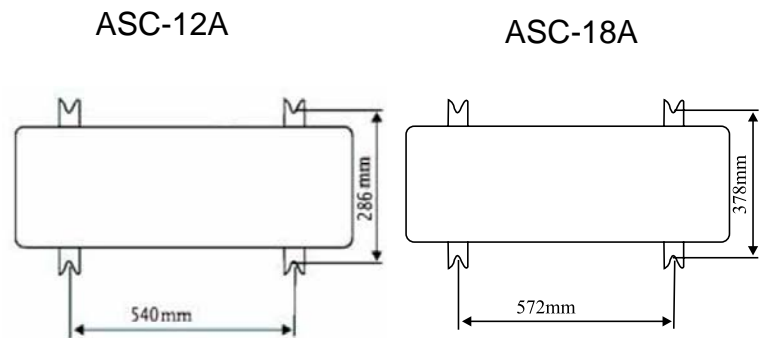

(Fig.8)

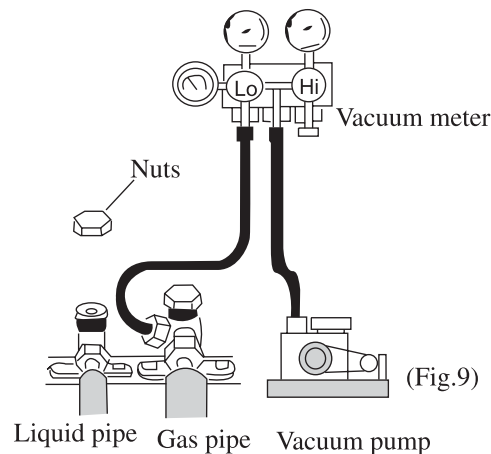

(Fig.9)

## Air purging and leakage test

1. Take out the nut cover of the inlet for refrigerant.
2. Connect the tube of the vacuum watch with the vacuum pump, having the low-pressure end linking to the inlet for refrigerant.
3. Starting the vacuum pump, when the indicator turns to -1 bar, closing the low pressure handle and stopping vacuumize. Keep for 15 minutes, ensuring the pressure of the vacuum watch remains.
4. Take out the valve cover of the gas valve together with the liquid valve.
5. Loosening the cord of liquid valve until the pressure rise to 0 bar.
6. Dismantle the tube from the cover of the inlet for refrigerant then, tighten the cover.
7. Loosen the valve cord of the gas valve as well as the liquid valve entirely.
8. Tighten the valve cover of the gas valve and liquid valve so as to check whether leakage occurred.

# Outdoor unit installation

## Electric wiring

- (1) Read the name plate carefully, then arrange wiring according to the "WIRING DIAGRAM".
- (2) A circuit breaker capable of shutting down power supply to the entire system must be installed.
- (3) Earth properly.
- (4) All wiring must be performed by a skilled electrician according to the "WIRING DIAGRAM". Wrong wiring may cause fire or electric shock.

## Connect the power connecting wires

- (1) Remove the front side plate (Fig.10)
- (2) Break through the hole for wires and put on rubber bush.
- (3) Pull all wires through the rubber bush.
- (4) Connect the outdoor unit according to the "WIRING DIAGRAM" of outdoor unit. Make sure to wire firmly.
- (5) Tighten the wires with clamp and clasp.

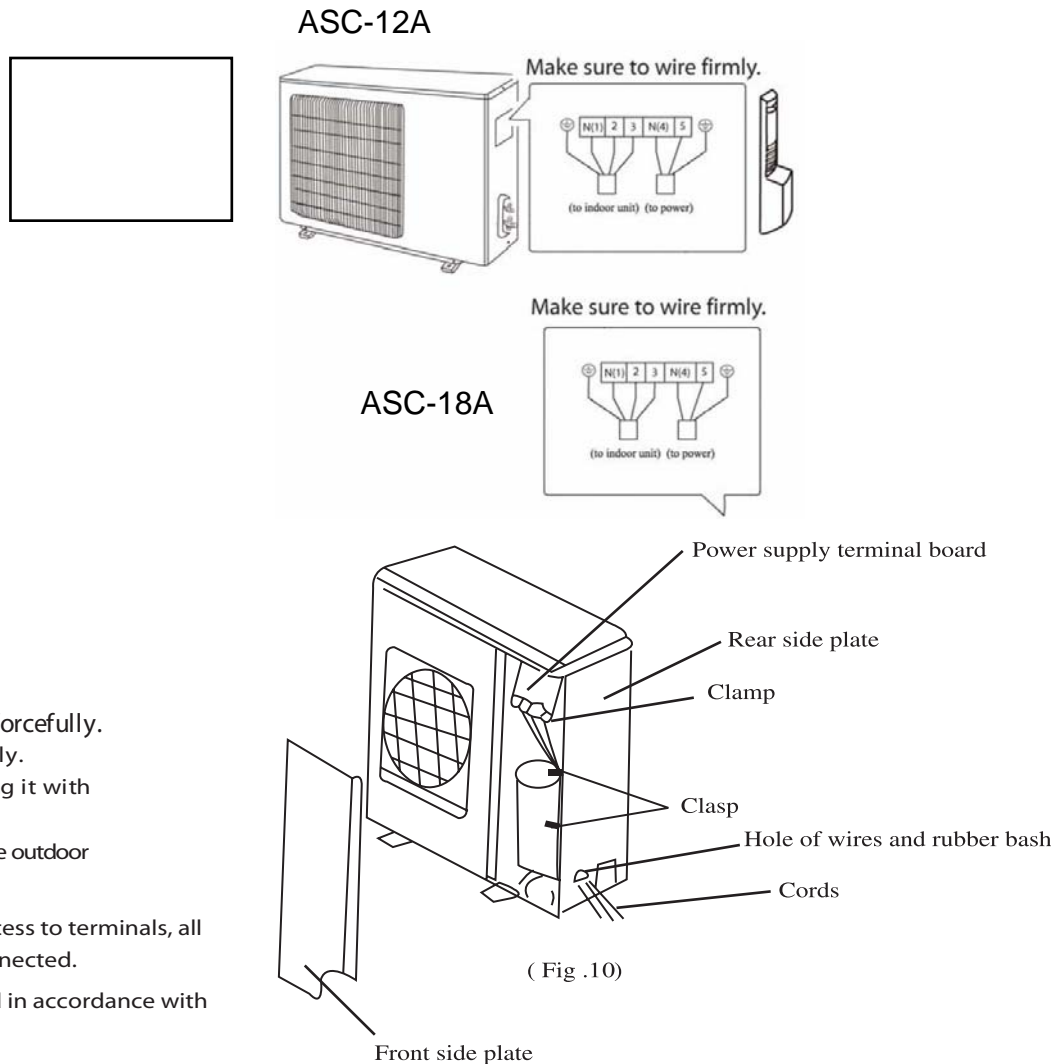

## Note

- (1) Earth the units firmly.
- (2) Wire the units firmly.
- (3) Don't pull the connector too forcefully.
- (4) Connect the other wires properly.
  - Do not pull the wire when fixing it with wire clamp and clasp.
  - Do not let the wire too loose in the outdoor unit.
- (5) Warning: before obtaining access to terminals, all supply circuits must be disconnected.
- (6) the appliance shall be installed in accordance with national wiring regulations.

# Test and check items after installation

## ● Test operation

### 1. Prepare for test

- (1) Do not turn on the power switch before all installation is finished.
- (2) Connect wires correctly and firmly.
- (3) Open the check valve.
- (4) Remove all dust.

### 2. Testing

- (1) Turn on the power switch and press “1/0” button.
- (2) Press “MODE” button select COOL,HEAT,FAN,etc to test whether it operates normally.

### 3. Emergency operation.

When the batteries fail or when the remote controller is missing, operate as shown below.

- \* On stopping you can press the “AUTO” button on cover NO. 11 unit! it is in “AUTO” mode.

The air conditioner select from COOL,HEAT,DRY,FAN modes automatically.

- \* On operating,press the “AUTO” button,the air conditioner will stop.

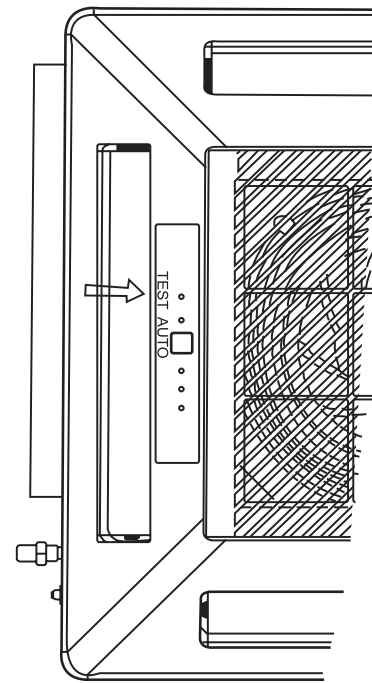

### Note

The “TEST” button on the cover No. 11 is specially for testing the air conditioner. When pressing it, the air conditioner will be forced to operate or stop. Do not press it when air conditioner is in normal operation.

**For the following items, take special care during construction and check after installation is finished.**

Items to check	If not properly done, what is likely to happen	Check
Is the indoor unit fixed firmly?	The unit may drop, vibrate or make noise.	
Is the gas leak test finished?	It may result in insufficient cooling.	
Is the unit fully insulated?	Condensate water may drip.	
Does drainage flow smoothly?	Condensate water may drip.	
Does the power supply voltage correspond to that shown on the nameplate	The unit may malfunction or the components burn out.	
Are wiring and piping correct?	The unit may malfunction or the components burn out.	
Is the unit safely grounded?	Risk of electric leakage.	
Is wiring size according to specifications?	The unit may malfunction or the components burn out.	
Is something blocking the air outlet or intake of either the indoor or outdoor units?	It may result in insufficient cooling.	
Have records of refrigerant piping length and additional refrigerant charge been made?	Volume of refrigerant charge in the system is not clear.	

### Note to the installer

Be sure to instruct the customer how to operate the system and show him/her the attached operation manual.